

VISION Industries

Product Catalogue

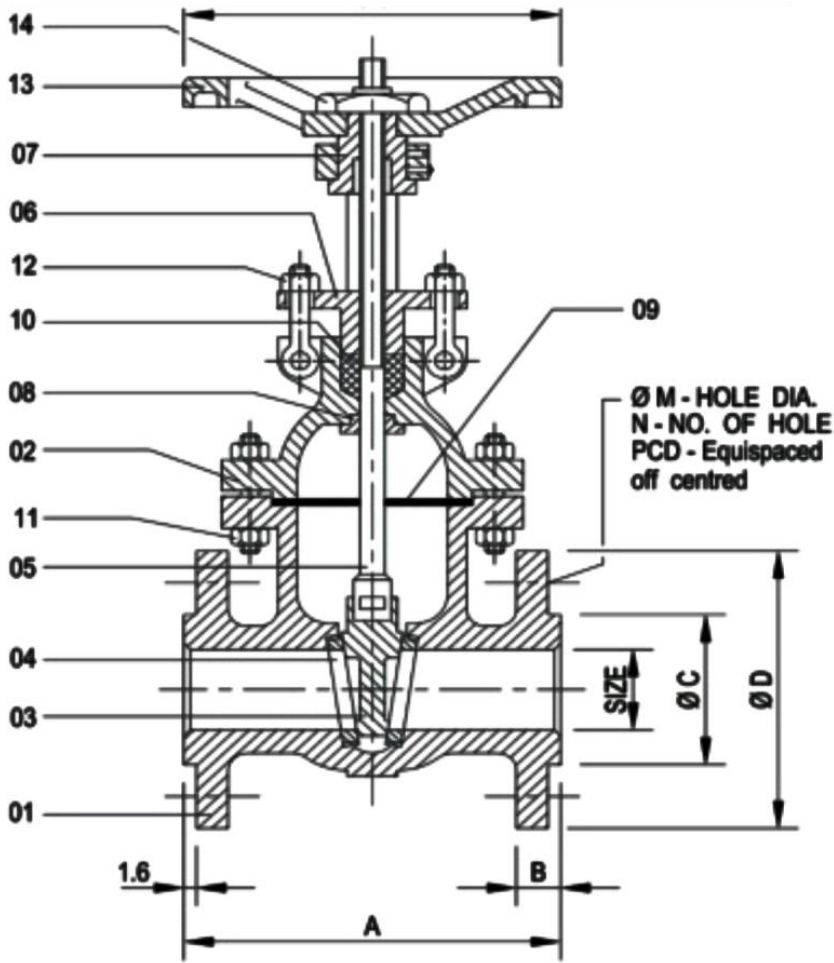

GATE VALVE



SUITABLE FOR

STEAM	WATER	OIL	AIR	GASES
●	●	●		

TEST PRESSURE

CLASS	WORKING PRESS.	TEMP.	HYD. TEST PRESS.	
			BODY	SEAT
150	150 PSIG	500° F	425 PSIG	300 PSIG
AIR TEST - SEAT		80 PSIG	± 10 PSIG	

NO.	DESCRIPTION	MATERIAL	QTY.
	BODY	ASTM A 216 Gr. WCB	1
2	BONNET	ASTM A 216 Gr. WCB	1
3	WEDGE	AISI 304 / AISI 316 / 13% CR. S.S.	1
4	SEAT RING	AISI 304 / AISI 316 / 13% CR. S.S.	2
5	STEM	AISI 304 / AISI 316 / 13% CR. S.S.	1
6	GLAND	CARBON STEEL	1
7	YOKE SLEEVE	AL. BRONZE / NI - RESIST	1
8	BACK SEAT BUSH	AISI 410	1
9	GASKET	SPIRAL WOUND METALIC	1
		GASKET	
10	GLAND PACKING	METALIC WIRE REINFORCED GRAPHITED ASBESTOS	—
11	BONNET STUD & NUT	ASTM A 193 Gr. B7	—
		ASTM A 194 Gr. 2H	
12	EYE BOLT & NUT	ASTM A 193 Gr. B7	2 SET
		ASTM A 194 Gr. 2H	
13	HAND WHEEL	SG IRON	1
14	HAND WHEEL NUT	CARBON STEEL	1

SIZE		CLASS - 150							
IN.	M.M.	A	B	OC	OD	OM	N	PCD	OJ
1"	25	127.0	11.0	51	108.0	16	4	79.2	123
1.1/2"	40	165.1	14.2	73	127.0	16	4	98.5	152
2"	50	177.8	15.7	92	152.0	19	4	120.6	203
2.1/2"	65	190.5	17.5	105	178.0	19	4	139.7	203
3"	80	203.2	19.0	127	190.5	19	4	152.4	254
4"	100	228.6	24.0	157	229.0	19	8	190.5	305
5"	125	254.0	24.0	186	254.0	22	8	215.9	305
6"	150	266.7	25.0	216	279.0	22	8	241.3	356
8"	200	292.1	28.5	270	343.0	22	8	298.4	356
10"	250	330.2	30.0	324	406.0	25	12	362.0	406
12"	300	355.6	32.0	381	483.0	25	12	431.8	457
14"	350	381.0	35.0	413	534.0	28	12	476.2	508
16"	400	406.4	36.5	470	597.0	28	16	539.7	508

ALL DIMENSION ARE IN MM

FORGE STEEL GATE VALVE

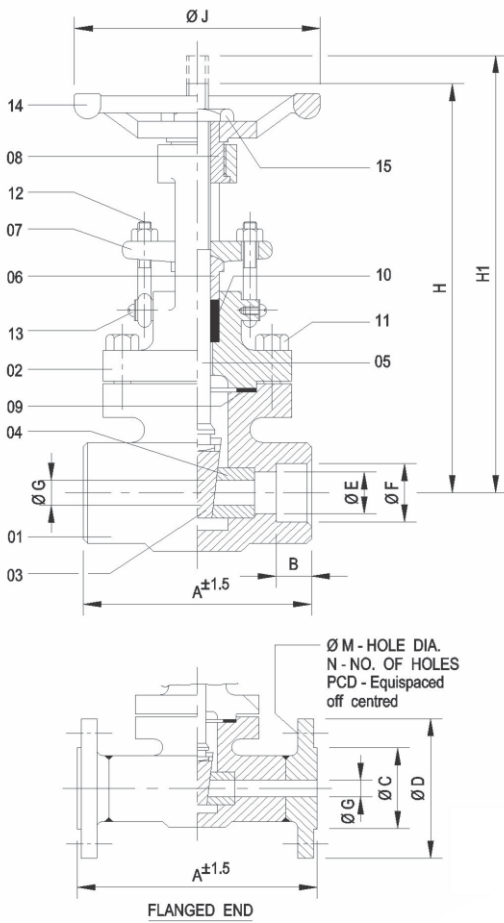

NO.	DESCRIPTION	MATERIAL	QTY.
1	BODY	FORGE STEEL A 105	1
2	BONNET	FORGE STEEL A 105	1
3	WEDGE	AISI 304 / AISI 316 / 13% CR. S.S.	1
4	SEAT RING	AISI 304 / AISI 316 / 13% CR. S.S.	2
5	STEM	AISI 304 / AISI 316 / AISI 410	1
6	GLAND BUSH	AISI 304 / AISI 316 / AISI 410	1
7	GLAND FLANGE	ASTM A 105	1
8	YOKE SLEEVE	AL. BRONZE / NI - RESIST	1
9	BONNET GASKET	SPIRAL WOUND S.S. 304 WITH CAF	1
10	GLAND PACKING	S.S. METAL WIRE BRAIDED ASBESTOS	—
11	BONNET STUD & NUT	ASTM A 193 Gr. B7 ASTM A 194 Gr. 2H	4 SET
12	EYE BOLT & NUT	FORGED C.S.	2 SET
13	SCREW & WASHER	M.S. GALVANISED	2 SET
14	HAND WHEEL	C.I. / C.S.	1
15	HAND WHEEL NUT	CARBON STEEL	1

SUITABLE FOR				
STEAM	WATER	OIL	AIR	GASES
●	●	●		

TEST PRESSURE	
BODY	SEAT
3000 PSIG	2000 PSIG
AIR TEST OF SEAT AT 100 PSIG	

SIZE		SCREWED / SOCKET WELD								
IN.	M.M.	A	B	E	OF	OG	H	H1	DT	OJ
1/2"	15	85	10	13	22.0	9.0	154	174	13	94
3/4"	20	90	13	15	27.5	14.0	160	185	13	94
1"	25	105	13	22	34.0	18.0	168	198	15	98
1.1/2"	40	128	13	36	48.6	32.0	231	274	25	142
2"	50	142	16	45	61.1	42.0	242	287	25	142

ALL DIMENSION ARE IN MM

GLOBE VALVE

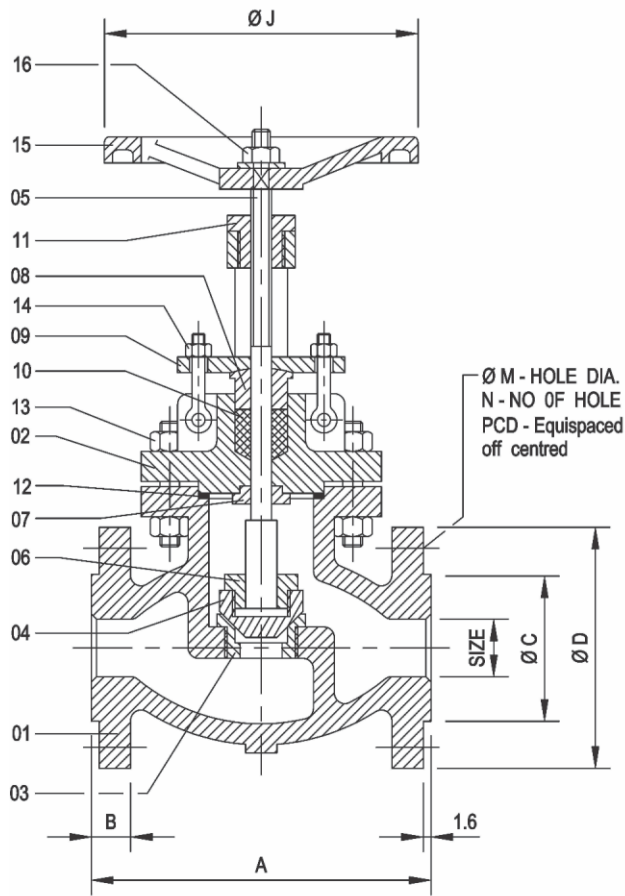

SUITABLE FOR

STEAM	WATER	OIL	AIR	GASES
●		●		

NO.	DESCRIPTION	MATERIAL	QTY.
	BODY	ASTM A 216 Gr. WCB	1
	BONNET	ASTM A 216 Gr. WCB	1
4	SEAT RING	AISI 304/ AISI 316/ 13% CR. S.S.	1
	DISC	AISI 304/ AISI 316/ 13% CR. S.S.	1
	STEM	AISI 304/ AISI 316/ 13% CR. S.S.	1
	DISC NUT	AISI 304/ AISI 316/ 13% CR. S.S.	1
	BACK SEAT BUSH	AISI 410 / 304 / 316	1
	GLAND BUSH	AISI 410 / 304 / 316	1
	GLAND FLANGE	CARBON STEEL	1
10	GLAND PACKING	MERALIC WIRE REINFORCED GRAPHITED ASBESTOS	—
11	YOKE SLEEVE	AL. BRONZE / NI - RESIST	1
12	BONNET GASKET	COMPRESSED ASBESTOS FIBRER / SOFT STEEL	—
13	BONNET STUD & NUT	CARBON STEEL	—
		CARBON STEEL	—
14	EYEBOLT & NUT	CARBON STEEL	2SET
15	HAND WHEEL	SG IRON	1
16	HAND WHEEL NUT	CARBON STEEL	1

TEST PRESSURE

CLASS	WORKING PRESS.	TEMP.	HYD. TEST PRESS. BODY	SEAT
150	150 PSIG	500° F	425 PSIG	300 PSIG
AIR TEST - SEAT 80 PSIG ± 10 PSIG				

SIZE		CLASS - 150							
IN.	M.M.	A	B	ØC	ØD	ØM	N	PCD	ØJ
1"	25	127	11.0	51	108.0	16	4	79.2	100
1.1/2"	40	165	14.2	73	127.0	16	4	98.5	135
2"	50	203	15.7	92	152.0	19	4	120.6	200
2.1/2"	65	216	17.5	105	178.0	19	4	139.7	250
3"	80	241	19.0	127	190.5	19	4	152.4	250
4"	100	292	24.0	157	229.0	19	8	190.5	300
5"	125	356	24.0	186	254.0	22	8	215.9	350
6"	150	406	25.0	216	279.0	22	8	241.3	350
8"	200	495	28.5	270	343.0	22	8	298.4	400
10"	250	622	30.0	324	406.0	25	12	362.0	450
12"	300	698	32.0	381	483.0	25	12	431.8	500

ALL DIMENSION ARE IN MM

FORGE STEEL GLOBE VALVE

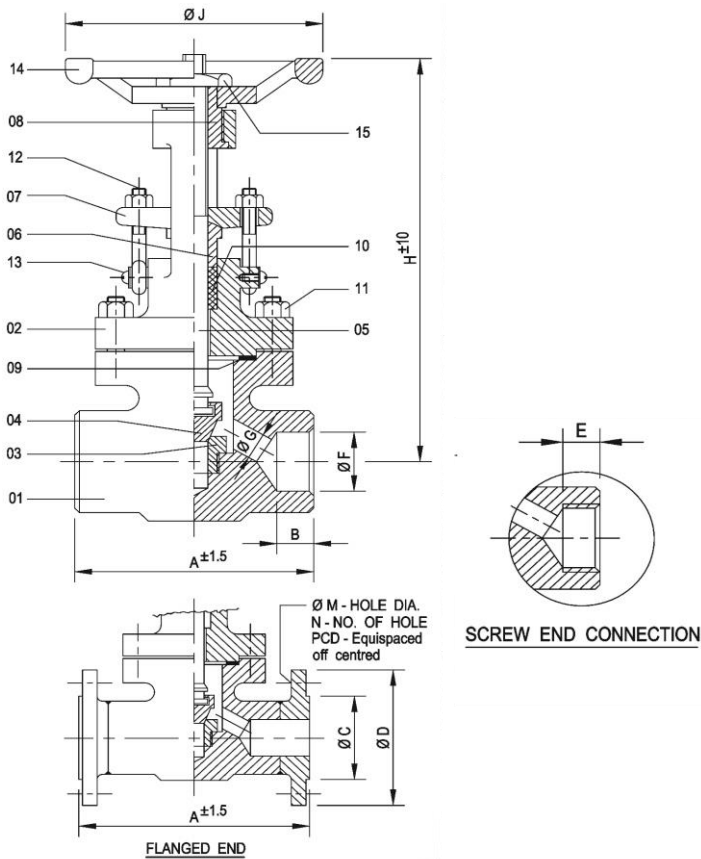

NO.	DESCRIPTION	MATERIAL	QTY.
	BODY	FORGE STEEL A 105	1
	BONNET	FORGE STEEL A 105	1
	SEAT RING	AISI 304 / AISI 316 / 13% CR. S.S.	1
4	DISC	AISI 304 / AISI 316 / 13% CR. S.S.	2
	STEM	AISI 304 / AISI 316 / 13% CR. S.S.	1
	GLAND BUSH	AISI 304 / AISI 316 / 13% CR. S.S.	1
	GLAND FLANGE	ASTM A 105	1
	YOKE SLEEVE	AL. BRONZE / NI - RESIST	1
	BONNET GASKET	SPIRAL WOUND S.S. 304 WITH CAF	1
10	GLAND PACKING	S.S. METAL WIRE BRAIDED ASBESTOS	—
11	BONNET STUD & NUT	ASTM A 193 Gr. B7 ASTM A 194 Gr. 2H	4 SET
12	EYE BOLT & NUT	FORGED C.S.	2 SET
13	SCREW & WASHER	M.S. GALVANISED	2 SET
14	HAND WHEEL	C.I. / C.S.	1
15	HAND WHEEL NUT	CARBON STEEL	1

SUITABLE FOR				
STEAM	WATER	OIL	AIR	GASES
●	●	●		

TEST PRESSURE	
BODY	SEAT
3000 PSIG	2000 PSIG
AIR TEST OF SEAT AT 100 PSIG	

SIZE		SCREWED / SOCKET WELD						
IN.	M.M.	A	B	E	ØF	ØG	H	ØJ
1/2"	15	85	10	13	22.0	9.0	150	78
3/4"	20	90	13	13	27.5	12.0	165	78
1"	25	105	13	15	34.0	17.5	185	100
1.1/2"	40	128	13	25	48.6	29.5	239	142
2"	50	142	16	25	61.1	35.0	248	142

ALL DIMENSION ARE IN MM

SWING CHECK VALVE

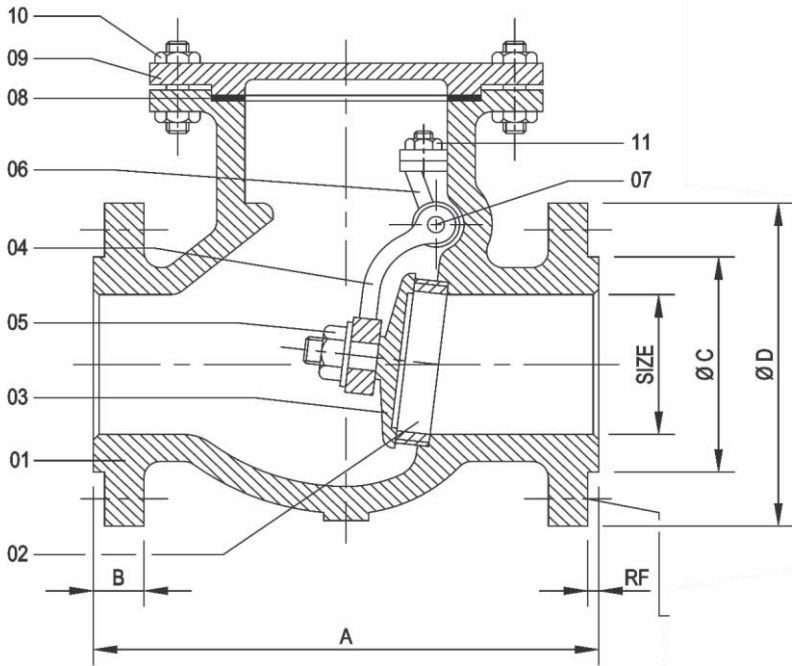

SUITABLE FOR				
STEAM	WATER	OIL	AIR	GASES
●	●	●		

HYDROSTATIC TEST PRESSURE			SERVICE RATING	
CLASS	BODY	SEAT	PRESSURE	TEMP.
150	425 PSIG	300 PSIG	150 PSIG	500° F
AIR TEST - SEAT			80 PSIG	± 10 PSIG

NO.	DESCRIPTION	MATERIAL	QTY.
1	BODY	ASTM A 216 Gr. WCB	1
2	SEAT RING	CARBON STEEL WITH 13% CR.	1
3	DISC	ASTM A 216 Gr. WCB WITH	1
		13% CR.	1
4	HINGE	ASTM A 216 Gr. WCB	1
5	DISC NUT	ASTM A 193 Gr. B7	1
		ASTM A 194 Gr. 2H	1
6	BRACKET	ASTM A 216 Gr. WCB	1
7	HINGE PIN	S.S. AISI 410	1
8	GASKET	COMPRESSED ASBESTOS FIBRE	1
9	COVER	ASTM A 216 Gr. WCB	1
10	COVER STUD & NUT	ASTM A 193 Gr. B7	-
		ASTM A 194 Gr. 2H	-
11	BRACKET STUD / NUT	ASTM A 216 Gr. WCB	1

SIZE		CLASS - 150						
IN.	M.M.	A	B	ØC	ØD	ØM	N	PCD
1.1/2"	40	165	14.2	73	127.0	16	4	98.5
2"	50	203	15.7	92	152.0	19	4	120.6
2.1/2"	65	216	17.5	105	178.0	19	4	139.7
3"	80	241	19.0	127	190.5	19	4	152.4
4"	100	292	24.0	157	229.0	19	8	190.5
5"	125	330	24.0	186	254.0	22	8	215.9
6"	150	356	24.0	216	279.0	22	8	241.3
8"	200	495	28.5	270	343.0	22	8	298.4
10"	250	622	30.0	324	406.0	25	12	362.0
12"	300	699	32.0	381	483.0	25	12	431.8
14"	350	787	35.0	413	533.0	28	12	476.2
16"	400	864	36.5	470	597.0	28	16	539.8

ALL DIMENSION ARE IN MM

FORGE STEEL CHECK VALVE

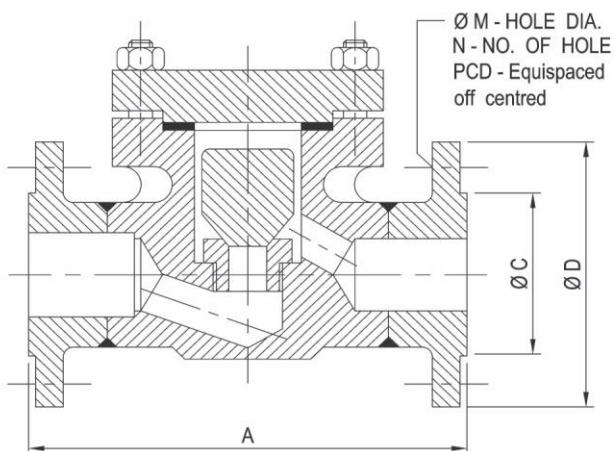
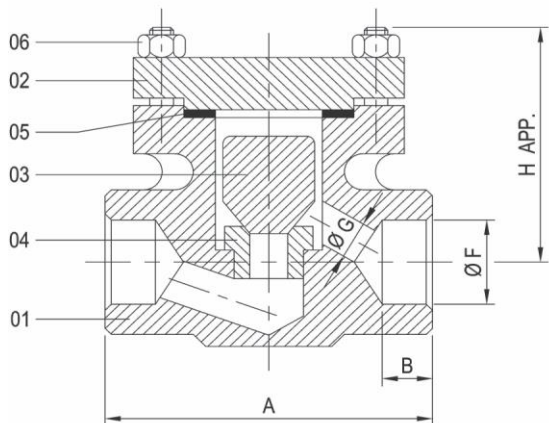

Ø M - HOLE DIA.
N - NO. OF HOLE
PCD - Equispaced
off centred

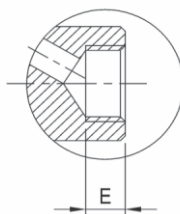

SCREW END CONNECTION

FLANGED END



SUITABLE FOR				
STEAM	WATER	OIL	AIR	GASES
●	●	●		

TEST PRESSURE	
BODY	SEAT
3000 PSIG	2000 PSIG
AIR TEST OF SEAT AT 100 PSIG	

NO.	DESCRIPTION	MATERIAL	QTY.
	BODY	FORGE STEEL A 105	1
2	COVER	FORGE STEEL A 105	1
	VALVE	AISI 304 / AISI 316 / AISI 410	1
4	SEAT RING	AISI 304 / AISI 316 / AISI 410	1
5	BONNET STUD & NUT	ASTM A 193 Gr. B7 ASTM A 194 Gr. 2H	1
6	COVER STUD & NUT	ASTM A 193 Gr. B7 ASTM A 194 Gr. 2H	1

SIZE		SCREWED / SOCKET WELD					
IN.	M.M.	A	B	E	OF	OG	H
1/2"	15	85	10	13	22.0	9.0	50
3/4"	20	90	13	13	27.5	12.0	62
1"	25	105	13	15	34.0	17.5	68
1.1/2"	40	128	13	25	48.6	29.5	100
2"	50	142	16	25	61.1	61.1	100

SIZE		CLASS - 150#					
IN.	M.M.	A	OC	OD	OM	N	PCD
1/2"	15	108	35	89.0	16	4	60.4
3/4"	20	118	43	98.5	16	4	70.0
1"	25	127	51	108.0	16	4	79.2
1.1/2"	40	165	73	127.0	16	4	98.5
2"	50	203	92	152.0	19	4	120.6

ALL DIMENSION ARE IN MM

BALL VALVE FLANGE END

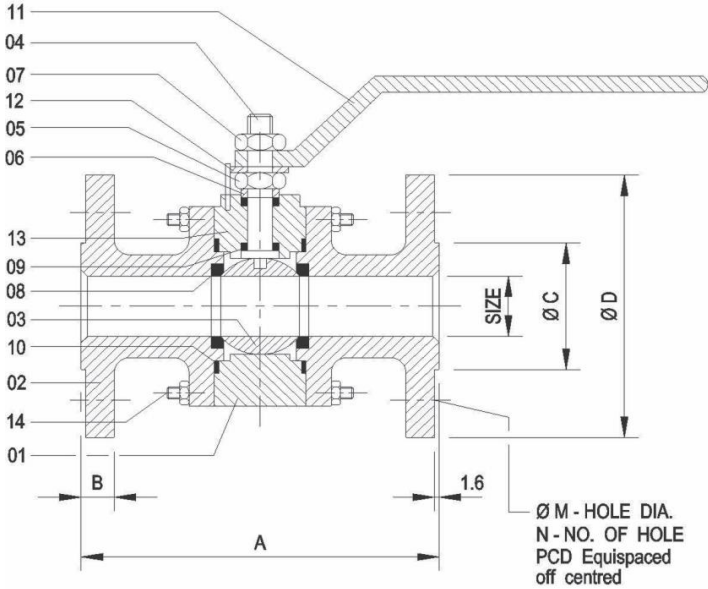

NO.	DESCRIPTION	MATERIAL	QTY.
1	BODY	C.I. / C.S. / S.S. 304 / S.S. 316	1
2	BODY CONNECTOR	C.I. / C.S. / S.S. 304 / S.S. 316	1
3	BALL	AISI 304 / AISI 316	1
4	STEM	AISI 304 / AISI 316	1
5	GLAND NUT	AISI 304 / AISI 316	1
6	GLAND BUSH	AISI 304 / AISI 316	1
7	LOCK NUT	AISI 304 / AISI 316	1
8	SEAT RING	PTFE	2
9	STEM RING	PTFE	2
10	BODY SEALANT RING	PTFE	1
11	WRENCH	C.S. / S.S. 304 / S.S. 316	1
12	STOP	C.S. / S.S. 304 / S.S. 316	1
13	STOPPER PIN	C.S. / S.S. 304 / S.S. 316	1
14	STUD & NUT	C.S. / S.S.	—

SUITABLE FOR				
STEAM	WATER	OIL	AIR	GASES
●	●	●		

SIZE		CLASS - 150						
IN.	M.M.	A	B	ØC	ØD	ØM	N	PCD
1/2"	15	108	10.0	35	89.0	16	4	60.4
3/4"	20	118	10.5	43	98.0	16	4	69.8
1"	25	127	11.0	51	108.0	16	4	79.2
1.1/4"	32	140	12.7	64	117.0	16	4	88.9
1.1/2"	40	165	14.2	73	127.0	16	4	98.5
2"	50	178	15.7	92	152.0	19	4	120.6
2.1/2"	65	191	17.5	105	178.0	19	4	139.7
3"	80	203	19.0	127	190.5	19	4	152.4
4"	100	229	24.0	157	229.0	19	4	190.5
5"	125	254	24.0	186	254.0	22	8	215.9
6"	150	267	25.0	216	279.0	22	8	241.3
8"	200	292	28.5	270	343.0	22	8	298.4
10"	250	330	30.0	324	406.0	25	12	362.0

ASME Class	HYDROSTATIC TEST PRESSURE IN KG/CM ² (PSIG)		PNEUMATIC LOW PRESSURE CLOSURE TEST PRESSURE IN KG/CM ² (PSIG)
	BODY	SEAT	
150	32 (450)	22 (315)	7 (100)

ALL DIMENSION ARE IN MM

BALL VALVE SINGLE PIECE SCREWED END

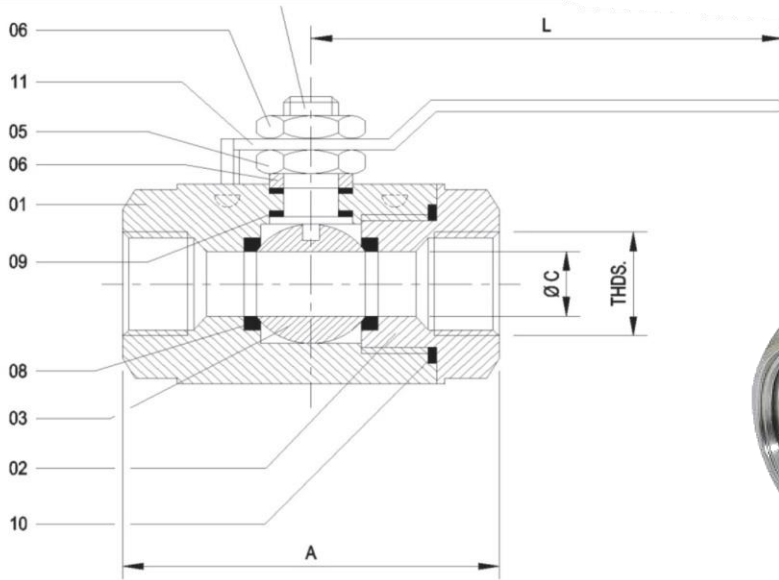

NO.	DESCRIPTION	MATERIAL	QTY.
	BODY	C.I. / C.S. / S.S. 304 / S.S. 316	1
	BODY / CONNECTOR	C.I. / C.S. / S.S. 304 / S.S. 316	1
	BALL	AISI 304 / AISI 316	1
4	STEM	AISI 304 / AISI 316	1
	GLAND NUT	AISI 304 / AISI 316	1
	GLAND BUSH	AISI 304 / AISI 316	1
	LOCK NUT	AISI 304 / AISI 316	1
	SEAT RING	PTFE	2
	STEM SEAL	PTFE	2
10	BODY SEALANT	PTFE	1
11	WRENCH	C.S. / S.S. 304 / S.S. 316	1

SUITABLE FOR				
STEAM	WATER	OIL	AIR	GASES
●	●	●		

SIZE		CLASS - 150			
IN.	M.M.	A	ØC	L	THDS. BSP/NPT
1/2"	15	72	12	125	1/2"
3/4"	20	77	18	125	3/4"
1"	25	87	25	125	1"
1.1/4"	32	101	32	175	1.1/4"
1.1/2"	40	117	38	175	1.1/2"
2"	50	127	50	175	2"
2.1/2"	65	151	63	252	2.1/2"
3"	80	171	75	252	3"

CLASS	HYDROSTATIC TEST PRESSURE IN KG/CM ² (PSIG)		AIR TEST PRESSURE IN KG/CM ² (PSIG) SEAT
	BODY	SEAT	
150	500 PSIG	230 PSIG	80 PSIG +_ 10PSIG

ALL DIMENSION ARE IN MM

FORGE STEEL BALL VALVE

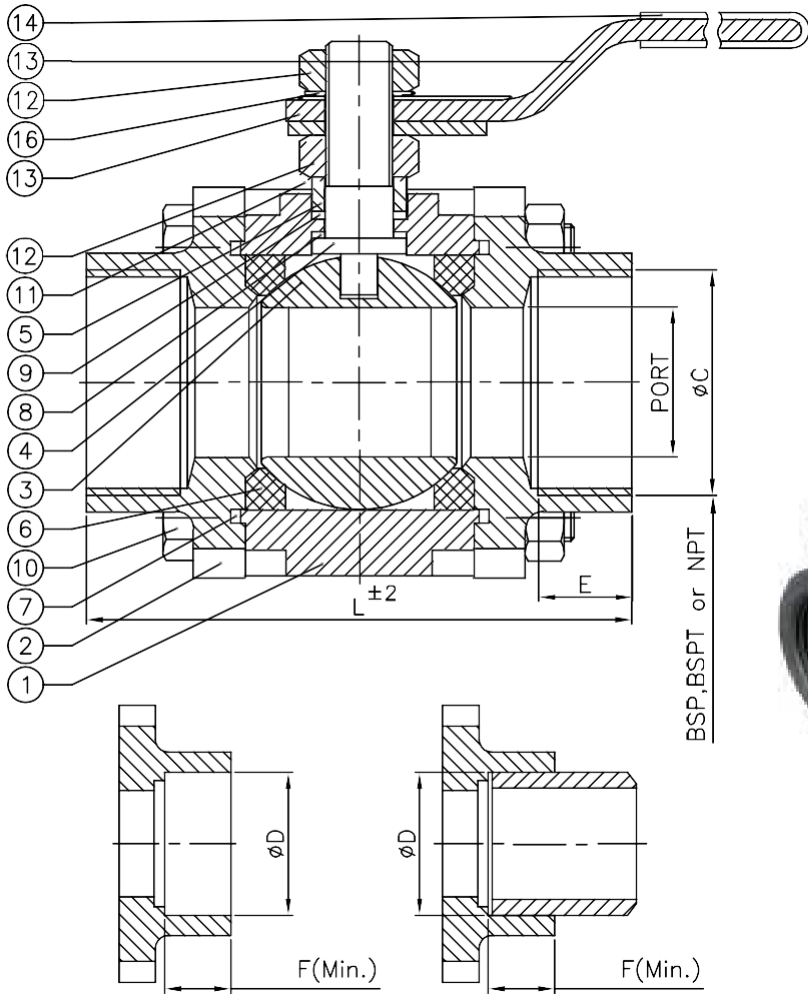

P.No.	Qty.	Nomenclature	Material
			ASTM A105
2	2		ASTM A105
3			AISI 304 / AISI 316
4			AISI 304 / AISI 316
5			AISI 304 / AISI 316
	2		Carbon filled PTFE
7	2		Glass filled PTFE/Graphite
8			35% Carbon filled PTFE
			Glass filled PTFE/Graphite
10	4-4	bolts &	ASTM A193 Gr B7 & ASTM A194 Gr 2H
		nut & stem	Carbon steel
12			Carbon steel
13			PVC
14			Carbon steel

TEST PRESSURE		
TESTING	BODY	SEAT
HYDRAULIC	104 Kg/cm ²	----
PNEUMATICS	--	7 Kg/cm ²

Max. cold working pressure : 69 Bar for size 15mm to 25mm
50 Bar for size 40mm & 50mm

SUITABLE FOR				
STEAM	WATER	OIL	AIR	GASES
●	●	●		

SIZE						
	10	12.5	17	24	30	37
L	72	75	92	105	115	125
	1/2"	3/4"	1"	1.1/4"	1.1/2"	2"
F	13.56	13.87	17.35	17.95	18.38	19.23
	Max.	22.22	27.56	34.29	43.05	49.15
	Min.	21.72	27.05	33.78	42.54	48.64
F(Min.)	9.65	12.7	12.7	12.7	12.7	15.75

All dimensions are in M.M.

BUTTERFLY VALVE

SIZE RANGE : 1 1/2" TO 48"

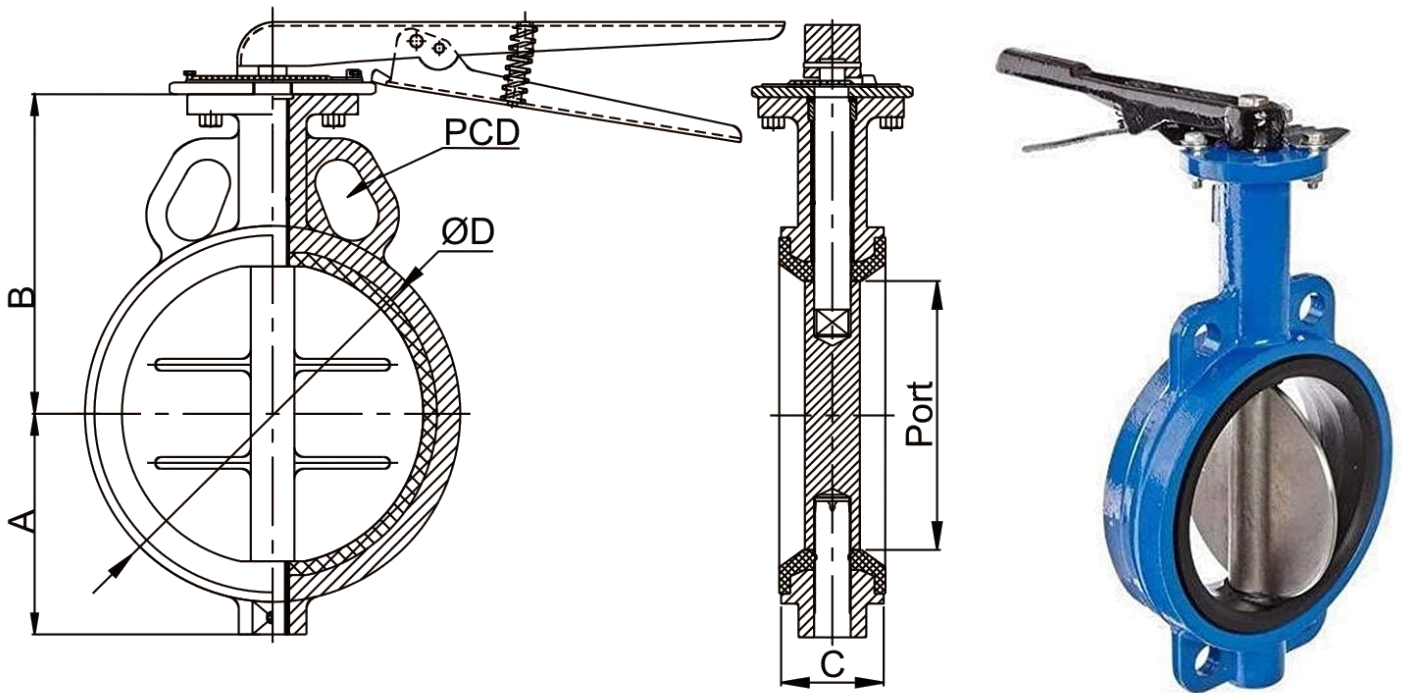

NO.	DESCRIPTION	MATERIAL
1	BODY	IS:210 Gr. FG. 200 CAST IRON ASTM - A 216 Gr. WCB (CAST STEEL) ASTM - A 351 Gr. CF8 (S.S. 304) ASTM - A 351 Gr. CF8M (S.S. 316)
2	DISC	S. G. IRON CAST STEEL S. S. 304 S. S. 316
3	SEAT	EPDM / VITON / HYELON
4	SHAFT	AISI 410 / AISI 304 / AISI 316 / AISI 316L
5	VALVE TYPE	CENTRIC DISC BUTTERFLY VALVE WITH RUBBER MOULDED
6	BODY TYPE	SHORT WAFER TYPE
7	SEAT TYPE	INTEGRALLY MOULDED WITH THE BODY (RENEWABLE SEAT)
8	END CONNECTION	WAFER TYPE SUIT 150#, TABLE 'D', TABLE 'E' & IS 6392 TABLE 11 (PN10 / PN 1.6)
9	PRESSURE RATING	PN 10 / PN 16
10	OPER. TEMP. RANGE	-20 °C TO 120 °C FOR NITRILE SEAT (DEPENDING ON MOC)
11	SEAT LEAKAGE	TIGHT SHUT OFF
12	OPERATION	LEVER OPERATED GEAR OPERATED

SIZE		A	B	C	ØD	P
IN.	M.M.					
1.1/2"	40	57	106	34	81.5	40
2"	50	64	117	44	95	50
2.1/2"	65	73	128	46	108	65
3"	80	78	129.5	46	124	80
4"	100	99.5	150	52	150	100
5"	125	113	161	56	182	125
6"	150	123.5	177	56	207	150
8"	200	156	206	60	258.5	200
10"	250	220	266	68	-	241
12"	300	246	287	78	-	286
14"	350	270	304	78	443	333
16"	400	295	365	102	488	382
18"	450	331	382	114	562	433
20"	500	371	420	127	600	476

ALL DIMENSION ARE IN MM

TEST PRESSURE BAR	
BODY / DISC	SEAT
24	17.6

SUITABLE FOR				
STEAM	WATER	OIL	AIR	GASES
	●	●	●	●

NON SLAM CHEKC VALVE

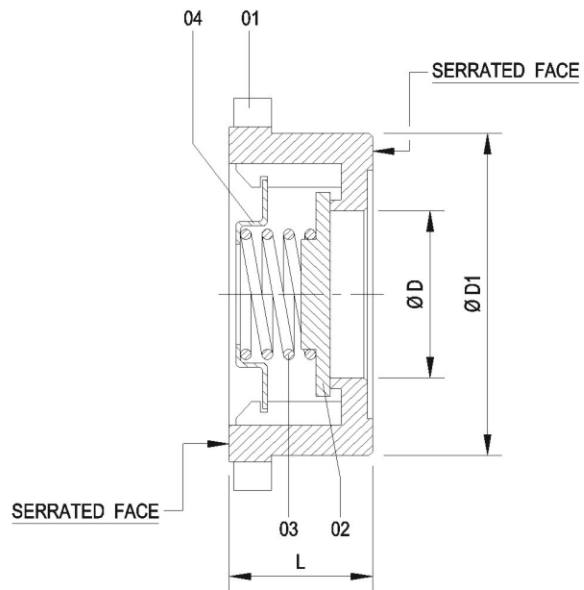
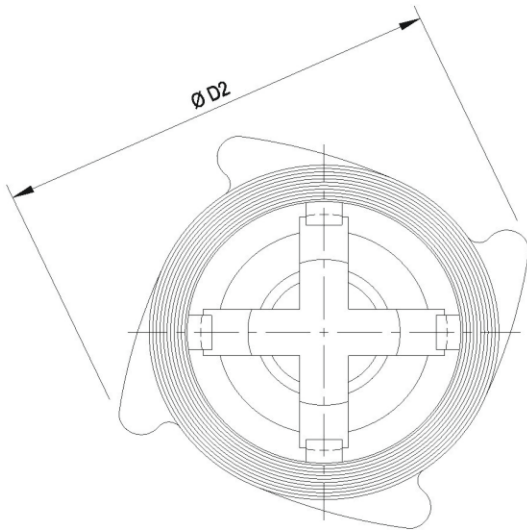

TEST PRESSURE				
CLASS	WORKING PRESS.	TEMP.	HYD. TEST PRESS.	
			BODY	SEAT
PN 40	40Kg / cm ²	300° C	77 Kg/cm ²	56 Kg/cm ²

SIZE					
IN.	M.M.	ØD	ØD1	ØD2	L
1/2"	15	15.0	38	60	16
3/4"	20	20.0	47	70	20
1"	25	24.0	55	80	22
1.1/2"	40	39.0	75	100	32
2"	50	50.0	93	115	40
2.1/2"	65	65.0	109	142	46
3"	80	76.0	127	154	50
4"	100	98.0	148	184	60
6"	150	150.0	202	230	74

ALL DIMENSION ARE IN MM

NO.	DESCRIPTION	MATERIAL	QTY.
	BODY	ASTM A 216 GR. WCB / ASTM A 351 - CF8 ASTM A 351 - CF8M	1
2	DISC	SS 304 / SS 316	1
3	SPRING	SS 304 / SS 316	1
4	SPRING WASHER	AISI 304 / AISI 316	1

SUITABLE FOR				
STEAM	WATER	OIL	AIR	GASES
●	●	●		●

ANGLE TYPE CONTROL VALVE

Size Range : 1/2" to 3"

Actuator

Body	SS 304 Pressed
Cover Flange	ASTM A351 Gr. CF8 (SS 304) Investment Die-Cast
Spring	Spring Steel (IS 4454 Gr. III)
Port Connection	1/4" BSP (NPT on request)
Operating Pressure	3.5 to 7 Bar
Position Indicator	Nylon
Operating Cycles	350 to 650 Cycles / Hr
Media	Dry Lubricated Air/Innert Gasses Asten Moisture Separators are advised to use in line

Valve

Size	1/2" to 3" Screwed / Flange
Body	ASTM A351 Gr. CF8 / CF8M / CF3M
Steam Packing	PTFE upto 180°C, Self-compensating (Spring Loaded)
Trim / Spindle	Stainless Steel 304/316/316L
Seat	Soft Seat (PTFE)
Gland Packing	Teflon 'V' seals, backed by graphite wiper seal (Self Compensating)
Body Test Pressure	24 Bar Maximum
End Connections	Female Screwed to BSP or NPT / Flange / Triclover
Working Fluid Press	Refer to table
Leakage	Drop tight / bubble tight, class IV ANSI B 16, 104, 1976
Operating Temp.	On steam - Continues 155°C, Intermittent 180°C Maximum (High Temp. above 180°C - On Request)
Media	Air, Water, Oil, Gas, Steam & Chemical

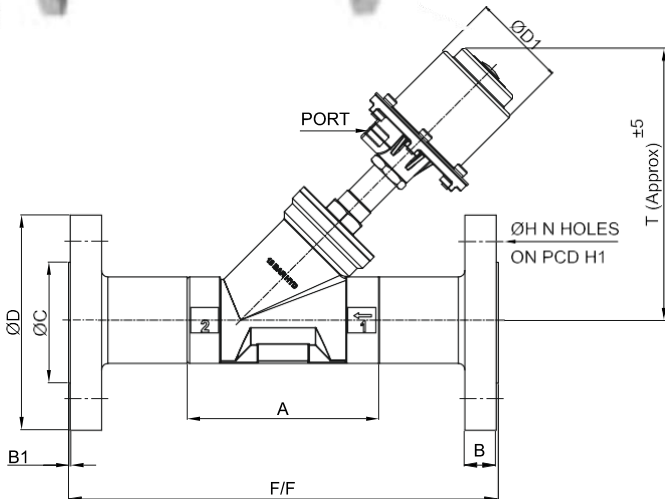

Technical Specification Table

Model	Valve Size	Orifice MM	Inlet Position	Max.Op. Press Low to Close Bar	Max.Op. Press Low to Open Bar	Flow Factor M3/hr	Air Consumption Lit./Cycle
AYCV - 15	1/2"	16	N/C	16	16	4.2	0.155
AYCV - 15		16	N/O	16	16	4.2	0.155
AYCV - 20	3/4"	16	N/C	16	16	5.5	0.155
AYCV - 20		16	N/O	16	16	5.5	0.155
AYCV - 25	1"	23	N/C	16	16	13.5	0.161
AYCV - 25		23	N/O	16	16	13.5	0.161
AYCV - 40	1.1/2"	34	N/C	15	15	31.9	0.172
AYCV - 40		34	N/O	10	10	31.9	0.172
AYCV - 50	2"	45	N/C	14	16	54.5	0.184
AYCV - 50		45	N/O	16	12	54.5	0.184
AYCV - 65	2.1/2"	62	N/C	14	16	54.5	0.184
AYCV - 65		62	N/O	16	12	54.5	0.184
AYCV - 80	3"	75	N/C	10	10	105	0.735
AYCV - 80		75	N/O	10	10	105	0.735

Position in Normally Close Valve

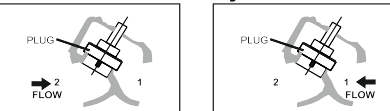

Position in Normally Open Valve



Dimensions :

SIZE		A	ACT. BORE	ØD1	F/F FLANGE	ØC	ØD	B	B1	H	H1	N	T FLANGE	PORT	Approx Weight SCREW	Approx Weight FLANGE
MM	IN.	SCREW														
15	1/2"	68	70	73	130	38	90	9.5	1.5	16	60	4	155	1/4" BSP	1.450	2.100
20	3/4"	75	70	73	150	43	98.5	10.5	1.5	16	70	4	160	1/4" BSP	1.450	2.300
25	1"	88	70	73	160	51	108	11	1.5	16	79.5	4	170	1/4" BSP	1.600	2.500
40	1.1/2"	125	70	73	189	73	125	11.5	1.5	16	98.5	4	191	1/4" BSP	2.350	3.950
50	2"	151	70	73	230	92	152	15.5	1.5	19	120	4	218	1/4" BSP	3.200	6.600
65	2.1/2"	195.5	120	124.5	216	104.8	178	15.9	1.5	19	139.7	4	230	1/4" BSP	-	-
80	3"	197	120	124.5	241.5	127	188	19	1.5	19	152.4	4	250	1/4" BSP	-	-

All Dimensions are in (mm.)

Power Plant



Sugar Mill



Pharmacy Industry



Steel Industry



Chemical Industry



Textile Industry



Vision Industries

Where flow and pressure under your control



114, Paiki Satyanarayan Esate, Nr. Kashiram mill , Narol,
Ahmedabad - 382405



+91 9512122507



Visionindustries1211@gmail.com



www.visionindustriesvalve.com

